

## Helmholtz Pair of Coils D 1000644

### Instruction sheet

07/12 ALF



- 1 Coil
- 2 4-mm-sockets
- 3 Stand rod
- 4 Securing sleeves

### 1. Description

The Helmholtz coils are used to create magnetic fields for deflecting electron beams and are attached to the tube holder D (1008507). The tube holder allows the coils to be set up in Helmholtz configuration to generate a highly uniform magnetic field perpendicular to the axis of the tube.

The two air-filled coils are made of lacquered copper wire on a plastic bobbin on an insulating stand rod with plastic sleeves for insertion into specially drilled holes on the demonstration tube holder. Connections are labelled from the start (A) to the end (Z) of the coil winding.

### 2. Technical data

Number of winding turns:	320 each
Coil diameter:	136 mm approx.
Rod:	145 mm x 8 mm Ø
Max. current:	
continuous:	1.0 A
momentary:	1.5 A (max. 10 min) 2.0 A (max. 3 min)
Effective impedance:	6 Ω approx.
Connectors:	4-mm socket
Magnetic flux <i>B</i> in Helmholtz-configuration:	$B = k * I$ , where $k = \text{appr. } 4,2 \text{ mT/A}$

### 3. Operation

- Insert the Helmholtz tubes into the holder with the connections facing outwards.
- Push the sleeves on the rod upwards and insert the rod into the holes at an angle.
- Push the sleeves into the holes to secure the coils.
- For series connection, connect socket Z of coil 1 to socket Z of coil 2 (refer to Fig 1.1).

Take into account the total current when calculating  $B$ .

- For parallel connection, connect socket A of coil 1 to socket Z of coil 2 and socket Z of coil 1 to socket A of coil 2 (refer to Fig 1.2).

To calculate  $B$  the total current  $2 I$  should be halved since both coils have the same resistance and half the current  $I$  passes through each one.

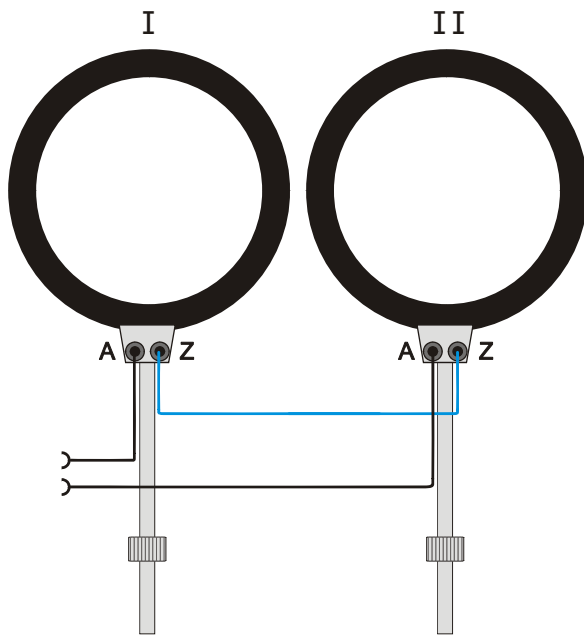

Fig. 1.1 Series connection

Make sure the connectors of each coil are facing outwards.

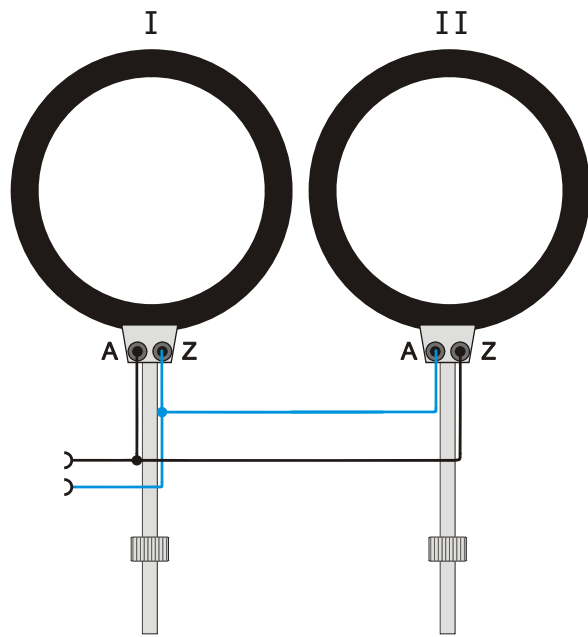

Fig. 1.2 Parallel connection