

## Power Supply Unit for Franck-Hertz Experiment (230 V, 50/60 Hz) Power Supply Unit for Franck-Hertz Experiment (115 V, 50/60 Hz)

1012819 (230 V, 50/60 Hz)  
1012818 (115 V, 50/60 Hz)

### Instruction sheet

01/14 ALF

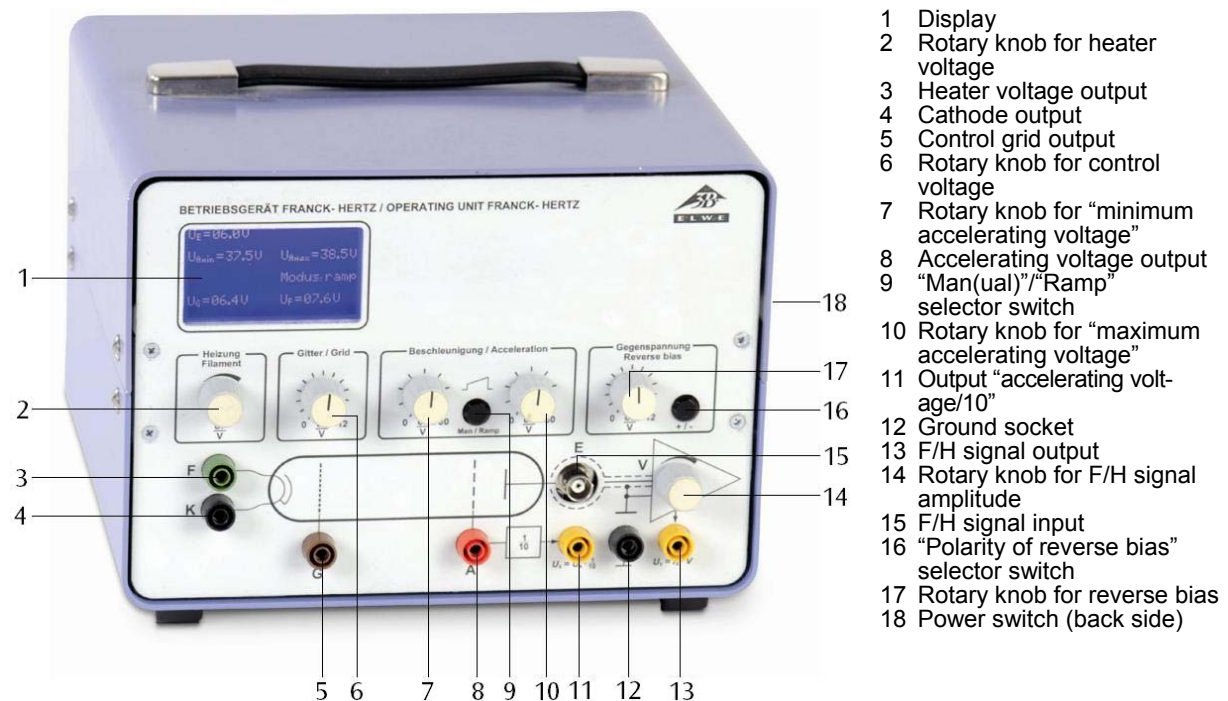

### 1. Safety instructions

The apparatus conforms to the safety requirements for electrical equipment for measurement, control and laboratory use of DIN EN 61010 part 1 and is classified as belonging to protection class I. It is intended for operation in dry rooms that are suitable for electrical equipment or installations.

Safe operation of the apparatus is guaranteed with correct handling. However, safety is not guaranteed if the apparatus is handled improperly or carelessly. If it is to be expected that safe operation is impossible (e.g., in case of visible damage), the apparatus is to be rendered inoperative immediately and to be safeguarded from unintentional use.

In schools and training institutions, operation of the

apparatus is to be responsibly supervised by trained personnel.

- Before first use, check if the apparatus is designed for local line voltage.
- Before start of the experiment, check the apparatus for damage.
- In case of visible damage or functional anomalies, render the apparatus inoperative immediately.
- The instrument may only be connected to the mains via a socket that has an earth connection.
- Allow only trained electronics specialists to open the apparatus.

## 2. Description

The Franck-Hertz control unit can be used to operate the mercury filled Franck-Hertz tube, the neon filled Franck-Hertz tube or the critical potential tubes S. It provides all the voltages needed to power the tubes and includes a highly sensitive built-in DC amplifier for measuring collector current.

### 1. Accelerating voltage $U_A$ :

Choice of 0 – 80 V stabilised DC voltage ("Manual" mode) or 50 Hz saw-tooth voltage ("Ramp mode"). At the oscilloscope output  $U_X$  this voltage is divided by 10.

### 2. Heater voltage $U_F$ :

DC voltage 0 – 12 V for the heater filament of the tube.

### 3. Countervoltage $U_E$ :

DC voltage of 0 – 12 V for reverse bias between grid and collector electrode.

### 4. Control voltage $U_G$ :

DC voltage of 0 – 12 V between the control grid and the cathode in the neon-filled Franck-Hertz tube

### 5. DC amplifier:

The DC amplifier provides a voltage proportional to the collector current, rated up to 10 mA. At the lowest amplification 1 V of voltage measured corresponds to an electron current of 38 nA approx. and at the highest amplification to an electron current of 12 nA approx.

The voltages can simultaneously be read off a display.

Additional measuring inputs are also available for the anode current and accelerating voltage.

The apparatus 1012818 is for operation with a mains voltage of 115 V ( $\pm 10\%$ ), and the unit 1012819 is for operation with a mains voltage of 230 V ( $\pm 10\%$ ).

## 3. Technical data

Mains voltage:	See back of chassis
Filament voltage $U_F$ :	0 – 12 V, continuously adjustable
Heater current:	0 – 2.5 A
Control voltage $U_G$ :	0 – 12 V, continuously adjustable
Accelerating voltage $U_A$ :	0 – 80 V, continuously adjustable or saw-tooth
Countervoltage $U_E$ :	0 – $\pm 12$ V, continuously adjustable, switchable polarity
Output $U_Y$ for collector current $I_E$ :	$I_E = U_A \cdot 38 \text{ nA/V}$ (0–12V)
Output $U_X$ for accelerating voltage $U_A$ :	$U_X = U_A / 10$
Outputs:	4 mm safety sockets
Input:	BNC socket
Dimensions:	160x132x210 mm <sup>3</sup> approx.
Weight:	3.4 kg approx.

## 4. Examples of use

### 4.1 Franck-Hertz tube with Hg filling

Additionally required:

1 F/H tube w. Hg filling a. heating chamber (230 V, 50/60 Hz)	1006795
or	
1 F/H tube w. Hg filling a. heating chamber (115 V, 50/60 Hz)	1006794
1 Analogue oscilloscope, 2x 30 MHz	1002727
1 HF patch cord, 1 m	1002746
2 HF patch cords, BNC / 4-mm plug	1002748

Safety leads for experiments

- Place front plate of the open side of the heating chamber and fix it in place with 6 knurled screws.
- Turn off the heating chamber and the control unit to begin with and turn all the knobs on the control fully to the left.
- Do not apply a voltage to the tube when it is still cold (the mercury inside may cause a short circuit).
- Connect terminals "A", "F" and "K" (refer to Fig. 1).
- Connect terminal "E" of the Franck-Hertz tube to the correct input on the control unit by means of an BNC cable.
- Connect the "FH Signal  $U_Y$ -out" terminal of the control unit to the Y input of the oscilloscope and terminal " $U_X$ " to the X input.
- Turn on the heating chamber. Set a temperature of about 210° C and wait for the tube to warm up (about 5 to 10 minutes).
- Turn on the control unit and the equipment should enter ramp mode.
- Set a filament voltage of 6 – 7 V. The indirectly heated cathode requires about 90 seconds to warm up, once the voltage is applied.
- Set the minimum acceleration voltage to zero, slowly increase the maximum acceleration voltage to 80 V.
- Do not, however, increase the accelerating voltage so much that self-discharge no longer occurs inside the tube. Any ionisation due to collisions will disrupt the curve.
- Set up the oscilloscope initially with settings of  $x = 1 \text{ V/div}$  and  $y = 1 \text{ V/div}$ .
- Observe the emergence of the maxima in the Franck-Hertz trace on the oscilloscope screen.
- Set up all the parameters, accelerating voltage, cathode filament, bias voltage and amplitude so that a trace with nicely delineated maxima and minima is obtained.

The procedure as described so far is a general setting procedure. Since the Franck-Hertz tubes are hand-made, there may be quite large differences in the optimum parameters from one tube to the next. The test report included with the tube should give some idea of where good results may be obtained for the tube in question.

The collector current displays regularly recurring, equidistant maxima and minima that are independent of the accelerating voltage. The interval between these peaks is 4.9 V. A contact potential of 2 V exists between the anode and cathode of the tube, which is why the first maximum only appears in the region of 7 V. The first maxima will be more obvious when the temperature of the heating chamber is lower.

#### 4.2 Franck-Hertz tube with Ne filling

Additionally required:

1 Franck-Hertz tube with Ne filling	1000912
1 Analogue oscilloscope, 2x 30 MHz	1002727
1 HF lead, 1 m	1002746
2 HF leads, BNC / 4-mm plug	1002748

Safety leads for experiments

- Start with the voltage supply unit switched off, and with all the voltage setting knobs fully to the left.
- Connect up the experiment as shown in Fig. 2.
- Turn on the equipment. It will start in ramp mode.
- Set up the oscilloscope in XY mode with  $x = 1 \text{ V/div}$  and  $y = 2 \text{ V/div}$ .
- Gradually increase the heater voltage till the filament starts to faintly glow red. Then wait 30 seconds till it reaches its operating temperature.
- Set the minimum acceleration voltage to zero, choose a maximum acceleration voltage of 80 V and set the control grid voltage to 9 V.

The ideal filament voltage should be between 4 and 12 V. This differs from tube to tube due to manufacturing tolerances.

- Gradually increase the filament voltage until an orange glow appears between the cathode and the grid. Then turn down the filament voltage till the glow disappears and only the filament is glowing.
- Gradually increase the decelerating voltage until the measured curve (of signal against accelerating voltage) is near horizontal.
- Increase the gain till the maxima of the Franck-Hertz curve can be seen on the oscilloscope screen.

#### 4.3 Critical potential tube

Additionally required:

1 Critical potential tube S with He-filling or	1000620
1 Critical potential tube S with Ne-filling	1000621
1 Tube holder S	1014525
1 Analogue oscilloscope, 2x 30 MHz	1002727
1 HF lead, 1 m	1002746
2 HF leads, BNC / 4-mm plug	1002748

Safety leads for experiments



#### Observation of potentials

critical

- Fit the critical potential tube into the tube holder, ensuring that the contact pins of the tube are correctly and fully engaged in the tube socket of the holder. The central guide pin of the tube should project slightly at the back of the holder.
- Start with the voltage supply unit switched off, and with all the voltage setting knobs fully to the left.
- Connect terminal F3 on the tube holder with output F of the control unit, connect C5 to output K (C5 and F4 are connected together internally inside the tube) and A1 to output A (refer to Fig. 3).
- Fit the screening frame over the tube, push its folded edge into the opening in the tube holder and connect it to the earth socket on the control unit.
- Connect the lead from the collector ring to the F/H signal input socket E.
- Connect the "FH Signal  $U_{\gamma}$ -out" terminal of the control unit to the Y input of the oscilloscope and terminal " $U_x$ " to the X input.
- Set up the oscilloscope initially with settings of  $x = 1 \text{ V/div}$  and  $y = 1 \text{ V/div}$ .
- Set the minimum acceleration voltage to about 15 V and the maximum acceleration voltage to about 28 V.
- Set a filament voltage of 2.7 V.
- Increase the filament voltage slightly and optimize the minimum and maximum acceleration voltage  $U_A$ .
- In the spectrum, identify the  $2^3\text{S}$  peak at 19.8 eV and determine its position  $t_1$  on the time axis.
- Identify the ionisation threshold at 24.6 eV.

#### Observation of ionisation

- In order to observe ionisation change the sign for the polarity of the counter voltage.

### 5. Storage, cleaning, disposal

- Keep the apparatus in a clean, dry and dust free place.
- Before cleaning the equipment, disconnect it from its power supply.
- Do not clean the unit with volatile solvents or abrasive cleaners.
- Use a soft, damp cloth to clean it.
- The packaging should be disposed of at local recycling points.
- Should you need to dispose of the equipment itself, never throw it away in normal domestic waste. Local regulations for the disposal of electrical equipment will apply.

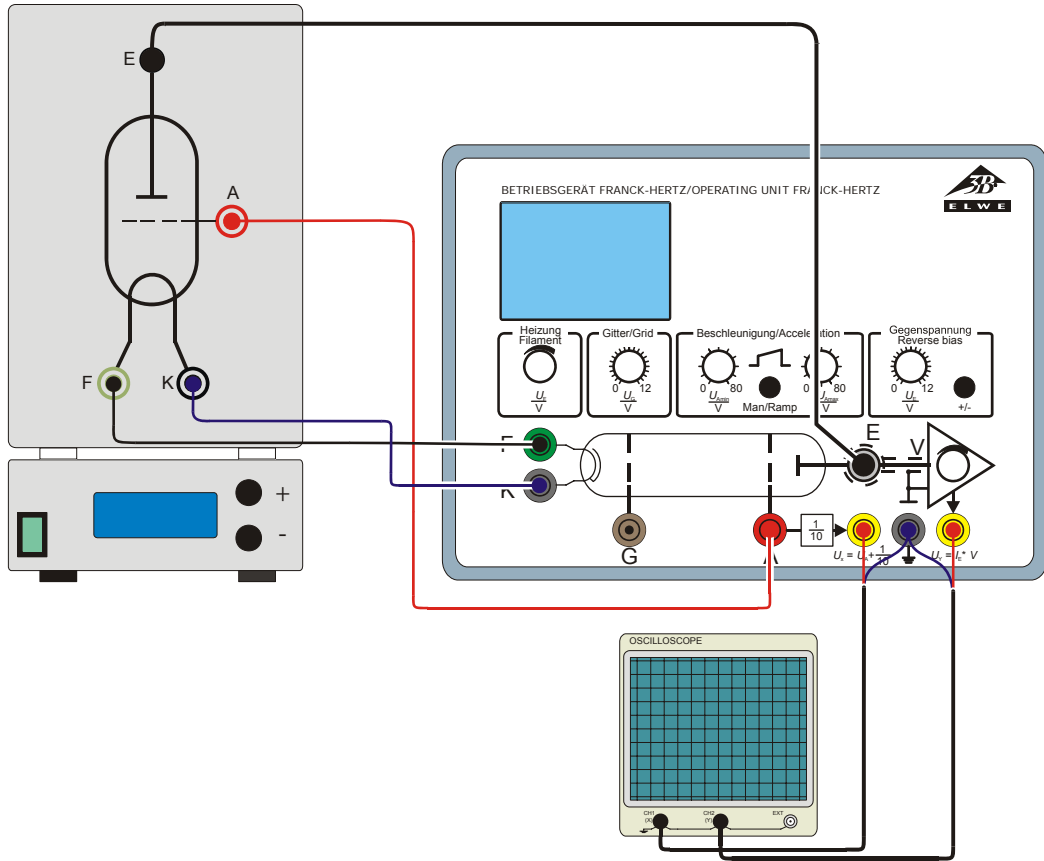

Fig. 1 Experiment set-up - Franck-Hertz tube filled with mercury

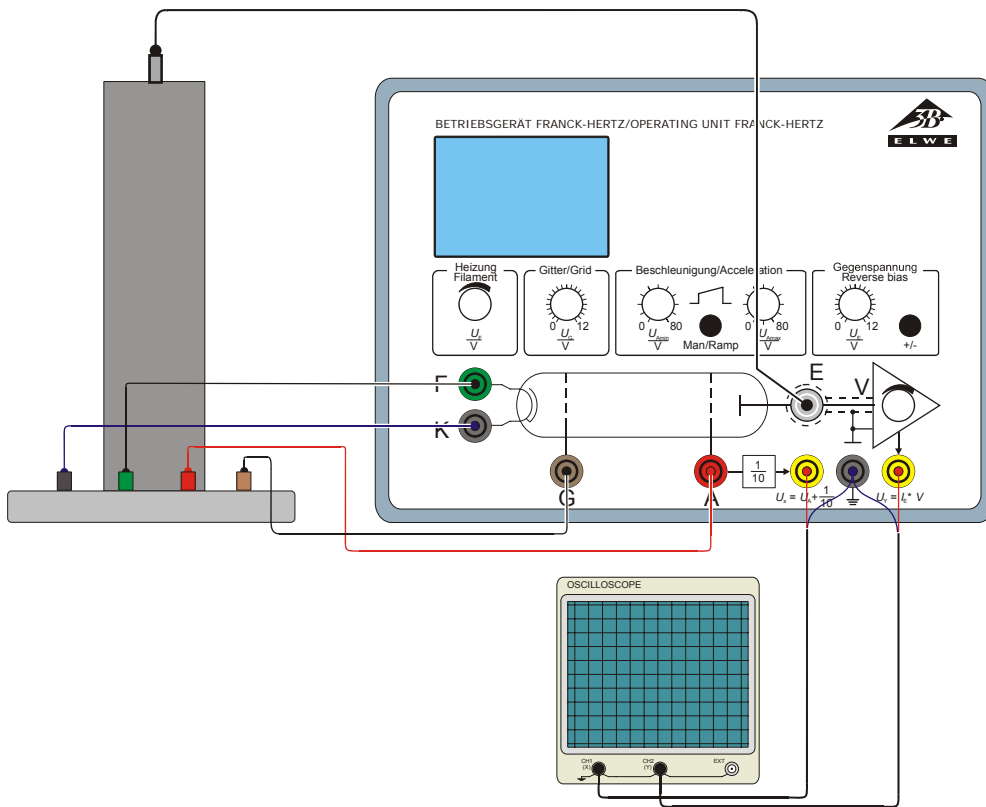

Fig. 2 Experiment set-up - Franck-Hertz tube filled with neon

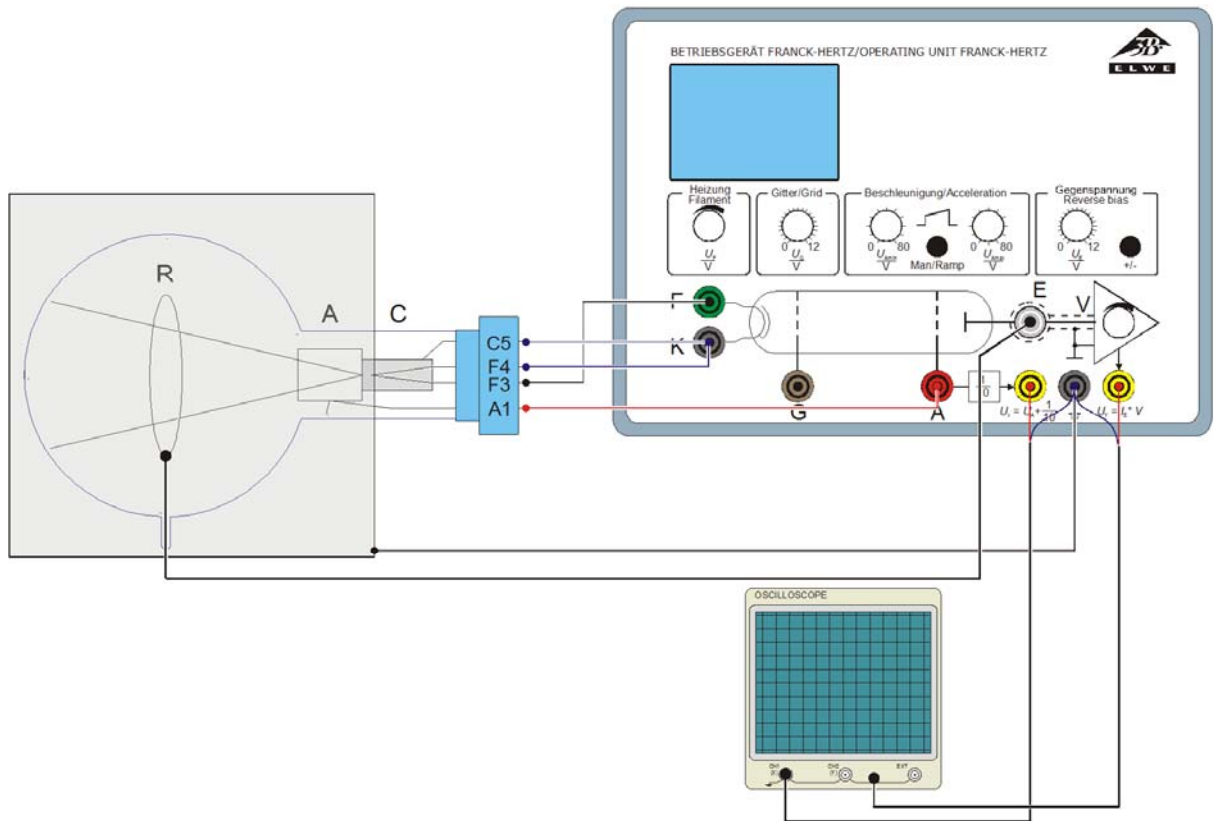

Fig. 3 Experiment set-up - critical potential tube

